

XGQT10

11.25° Elbow

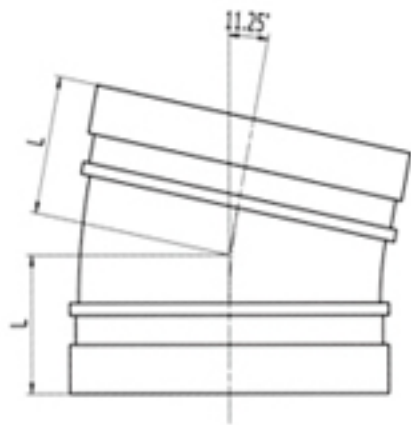

Nominal Size mm/in	Pipe O.D mm/in	Working Pressure PSI/MPa	Dimension L mm/in
			11.25° Elbow
25	33.7	300	35
1	1.315	2.07	1.378
32	42.4	300	35
1¼	1.66	2.07	1.378
40	48.3	300	35
1½	1.9	2.07	1.378
50	60.3	300	35
2	2.375	2.07	1.378
65	73	300	38
2½	2.875	2.07	1.496
65	76.1	300	38
3OD	3	2.07	1.496
80	88.9	300	38
3	3.5	2.07	1.496
100	114.3	300	45
4	4.5	2.07	1.772
125	139.7	300	51
5½OD	5.5	2.07	2.008
150	165.1	300	51
6½ OD	6.5	2.07	2.008
150	168.3	300	51
6	6.625	2.07	2.008
200	219.1	300	51
8	8.625	2.07	2.008
250	273	300	54
10	10.75	2.07	2.126
300	323.9	300	57
12	12.75	2.07	2.244